

## Mechanical Tees

*Shurjoint mechanical tees provide a fast and easy mid-point branch outlet, eliminating the need for welding or the use of multiple fittings.*

The Model M21 features a female threaded outlet and M22 features a grooved end outlet. Model 7721 (female threaded outlet) and 7722 (grooved end outlet) are available in 8" sizes. The Model 723 Saddle-let features a compact-design for making direct connections to sprinkler heads, drop nipples and or gauges.

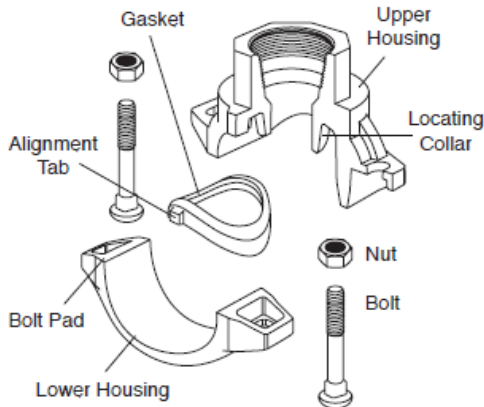

When bolts are tightened with a proper torque, the outlet housing makes metal to metal contact with the outer surface of the pipe.

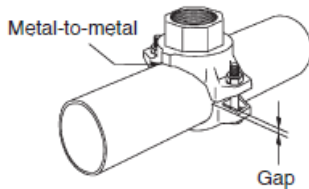

It is normal to see bolt pad gaps, though they should be equal on both sides of the mechanical tee.



The hole must be cleanly cut using the correct size hole-saw and shall have a smooth edge. Never use a torch for cutting a hole.

## Hole-cutting

The hole-cut method of pipe preparation is required when using mechanical tees, mechanical crosses, and saddle-lets. The method of pipe preparation requires the cutting or drilling of a specified hole size on the centerline of the pipe.

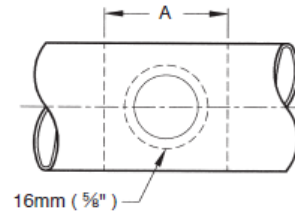

Always use the correct hole saw size as shown in Table 1 and Table 1-b and never use a torch for cutting a hole. After the hole has been cut all rough edges must be removed and the area within 5/8" (16mm) of the hole should be inspected to ensure a clean smooth surface, free



Ridgid Model No. HC-300  
Hole Cutting Tool

of any indentations or projections that could affect proper gasket sealing. The area within the "A" dimension should also be inspected and must be free of dirt, scale or any imperfection that could affect proper seating or assembly of the fitting.

**Hole Size:** The hole sizes are dictated by the branch size of the mechanical tee.

Table 1 Hole Sizes for Mechanical Tees unit: mm/in

Branch Size	Hole Dimensions		Surface Preparation "A"
	Hole Saw Size	Max. dia. Allowed	
15, 20, 25 ½, ¾, 1	38 1½	41 1⅝	89 3½
32, 40 1¼, 1½	51* 2	54* 2⅛	102 4
50	64 2	67 2⅝	114 4½
65	70 2½	73 2⅞	121 4¾
80	89 3	92 3⅝	140 5½
100	114 4	118 4⅝	165 6½

\*See Table 1-b for exception.

Table 1-b Exception

Branch Size	Hole Dimensions		Surface Preparation "A"
	Hole Saw Size	Max. dia. Allowed	
50x32 / 50x40 2 x 1¼ / 2x 1½,	45 1¾	47 1⅞	102 4